

ESCAPADE 2

design Zeno NUGARI

rochebobois
PARIS



ESCAPADE 2

rochebobois
PARIS

design Zeno NUGARI



ESCAPADE 2

rochebobois
PARIS

design Zeno NUGARI



INFORMATIONS TECHNIQUES / TECHNICAL SPECIFICATIONS / FICHA TECNICA :

Structure: Sapin massif
Suspensions : Sangles élastiques entrecroisées HR
Garnissage assise: Mousse 30CR et ouate
Garnissage dossier: 100% plumes, structure en métal
Piétement: Hêtre massif teinté noir

Structure: Solid fir wood,
Suspension: HR cross-webbing elastic straps
Seat cushions: Foam 30CR and batting
Back cushions: 100% feathers, structure in metal
Base: Stained solid beech black

Estructura: Abeto macizo
Suspension: Cinchas elásticas entrecruzadas HR
Interior cojines de asiento: Espuma 30CR y guata
Interior cojines de respaldo: 100% de plumas, estructura en metal
Patas: Haya maciza tintada negro

OBSERVATIONS / OBSERVATIONS / OBSERVACIONES :

- Fabrication Européenne
- Entièrement déshabillable
- Coussins de dossier librement positionnables sur les éléments
- Modèle réalisable dans l'ensemble des revêtements de la collection ROCHE BOBOIS

- Manufactured in Europe
- Entirely removable covers
- Backrests can be positioned freely on the elements
- Model available in all materials from the Roche Bobois collection.

- Fabricación europea
- Totalmente desenfundable
- Los cojines de respaldo se pueden poner libremente sobre los elementos
- Modelo realizable en el conjunto de los revestimiento de la colección ROCHE BOBOIS

OPTIONS / OPTIONAL / OPCIONES :

- Eléments disponibles dans 3 Profondeurs : P.120 cm, P.110 cm et P.100 cm
- Elements available in 3 Depths: D.120 cm, D.110 cm and D.100 cm
- Elementos disponibles en 3 Profundidades: P.120 cm, P.110 cm y P.100 cm

ESCAPADE 2

design Zeno NUGARI

NOTICE D'UTILISATION DES TISSUS / INFORMATION REGARDING USE OF FABRICS / INFORMACIÓN DEL USO DE LAS TELAS

1) Sens de coupe des tissus / Direction of the cut / Sentido del corte de las telas:

Tous les tissus utilisés pour la fabrication du modèle ESCAPADE 2 sont coupés dans le sens de la longueur des pièces de tissu, comme indiqué ci-dessous :

All fabrics used on the ESCAPADE 2 sofa are cut lengthwise, as shown below:

Todas las telas utilizadas para la fabricación del modelo ESCAPADE 2 se cortan en el sentido largo de las piezas de tela, como indicado más abajo:

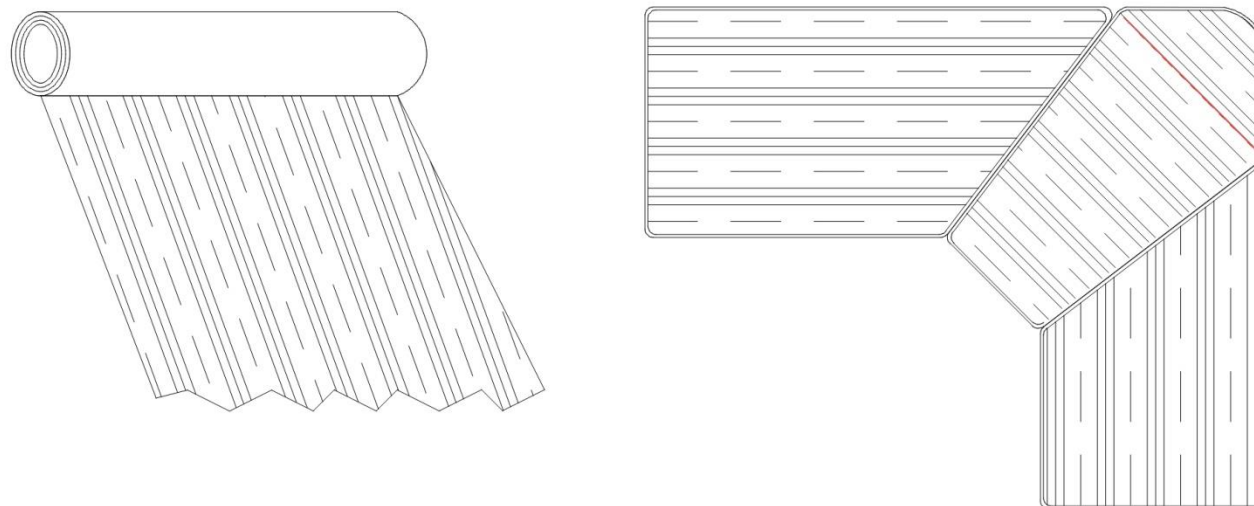

ESCAPADE 2

design Zeno NUGARI

2) Particularité de l'élément d'angle / Distinctive feature of the corner element / Particularidad del elemento de ángulo:

La Profondeur de l'élément d'angle étant supérieure à la laize des tissus, il est obligatoire de l'habiller avec 2 morceaux de tissus différents cousus ensemble. Il est impossible de les raccorder entre eux.

The depth of the corner element is superior to the width of the fabrics used. It is therefore necessary to upholster it with two different pieces of fabrics sewed together. It is not possible to have them match.

La profundidad del elemento de ángulo como es superior al ancho de las telas, es obligatorio ponerle 2 trozos de telas diferentes cosidos juntos. Es imposible casarlas entre ellas.

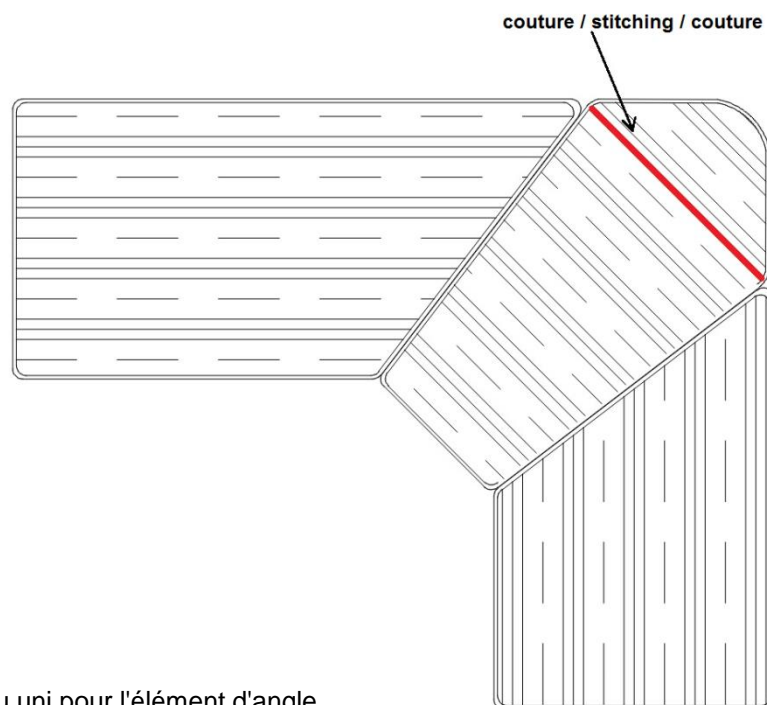

Pour cette raison, nous vous conseillons de toujours utiliser un tissu uni pour l'élément d'angle.

This is the reason why we recommend that you always use a plain fabric for the corner element.

Por esta razón, les aconsejamos que siempre utilicen una tela lisa para el elemento de ángulo.

ESCAPADE 2

design Zeno NUGARI

Par ailleurs, il est impossible de raccorder les tissus entre les 2 éléments à pans coupés

It is also not possible to match fabrics between the 2 angled cut elements

Por otra parte, es imposible casar las telas entre 2 elementos recortados.



3) Revêtements déconseillés / Recommended materials / Revestimientos desaconsejados:

L'utilisation de velours ou de tissus à poils longs n'est pas conseillée. En effet, le frottement de l'antidérapant placé sous le support des coussins de dos pourrait, à la longue, détériorer ces tissus.

The use of velvet or fabrics with long pile (such as faux-fur, shaggy materials) is not recommended. These materials will cause friction with the nonskid product used under the support of the back cushions and it may deteriorate them over time.

El uso del terciopelo o de tela con pelos largos, no es aconsejable. La fricción del anti-deslizante puesto bajo el soporte de los cojines de respaldo podría, a la larga, deteriorar estas telas.

ESCAPADE 2

design Zeno NUGARI

GRAND CANAPE 3 PLACES
LARGE 3-SEAT SOFA
GRAN SOFÁ 3 PLAZAS

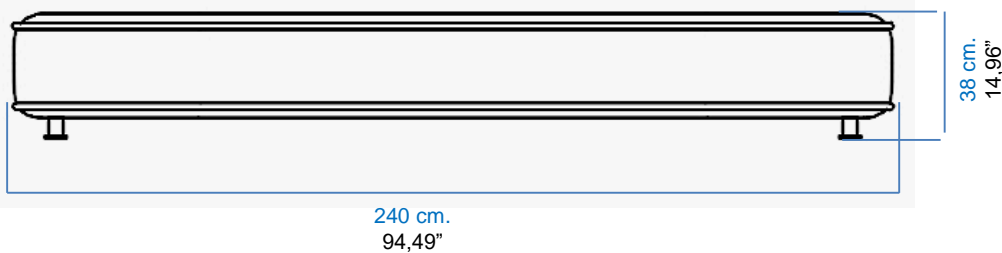

CANAPE 3 PLACES
3-SEAT SOFA
SOFÁ 3 PLAZAS

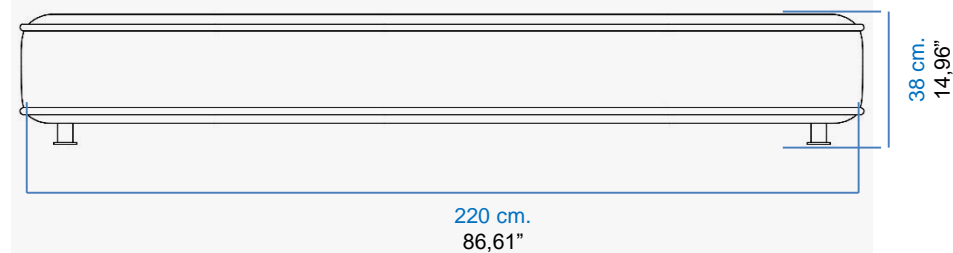

VUE DE COTE
SIDE VIEW
VISTA LATERAL

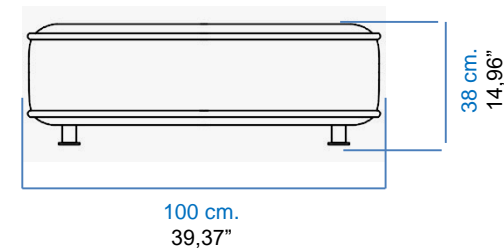
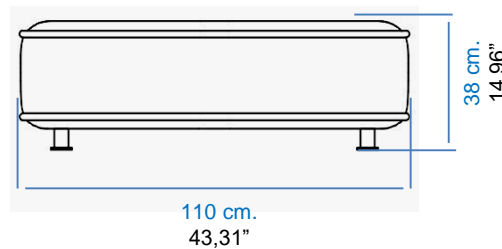
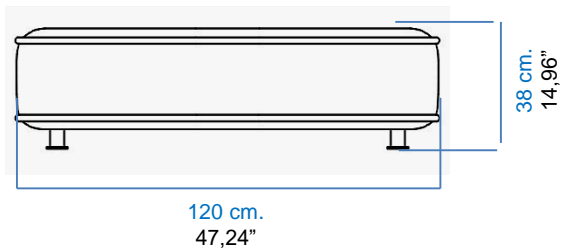

ESCAPADE 2

design Zeno NUGARI

CANAPE 2,5 PLACES
2,5 -SEAT SOFA
SOFÁ 2,5 PLAZAS

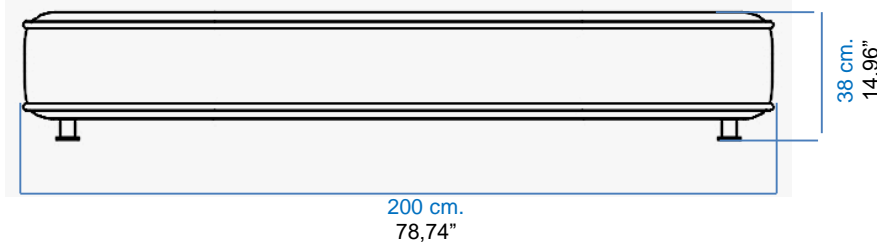

CANAPE 2 PLACES
2 -SEAT SOFA
SOFÁ 2 PLAZAS

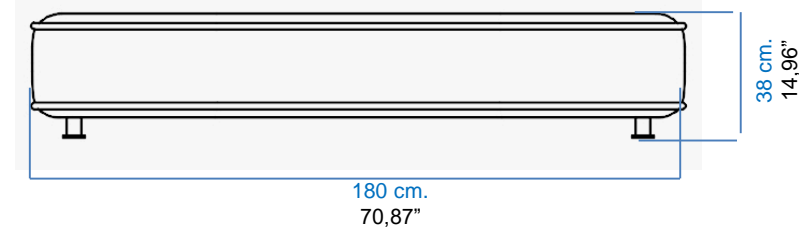

CANAPE 1 PLACE
1 -SEAT SOFA
SOFÁ 1 PLAZA

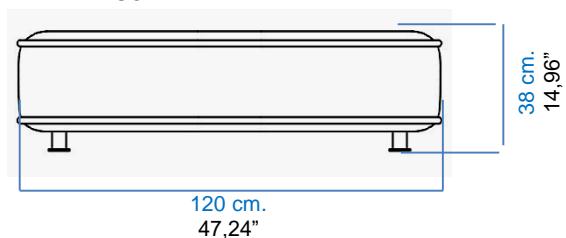

VUE DE COTE
SIDE VIEW
VISTA LATERAL

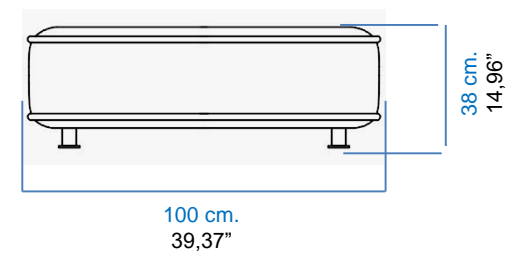
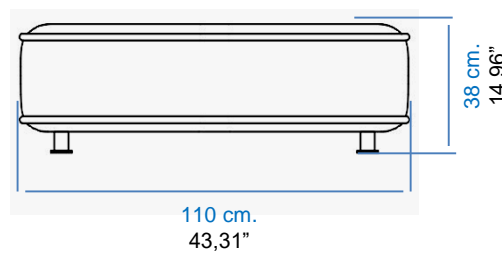
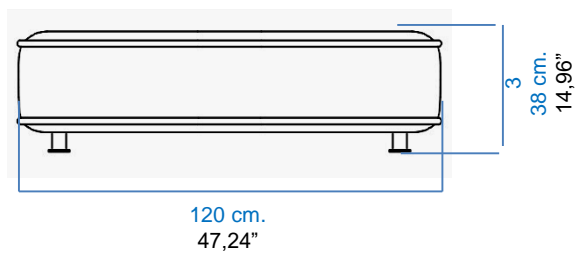

ESCAPADE 2

design Zeno NUGARI

COMPOSITION D'ANGLE PROF.110
CORNER COMPOSITION DEPTH.110
COMPOSICIÓN DE ÁNGULO PROF.110

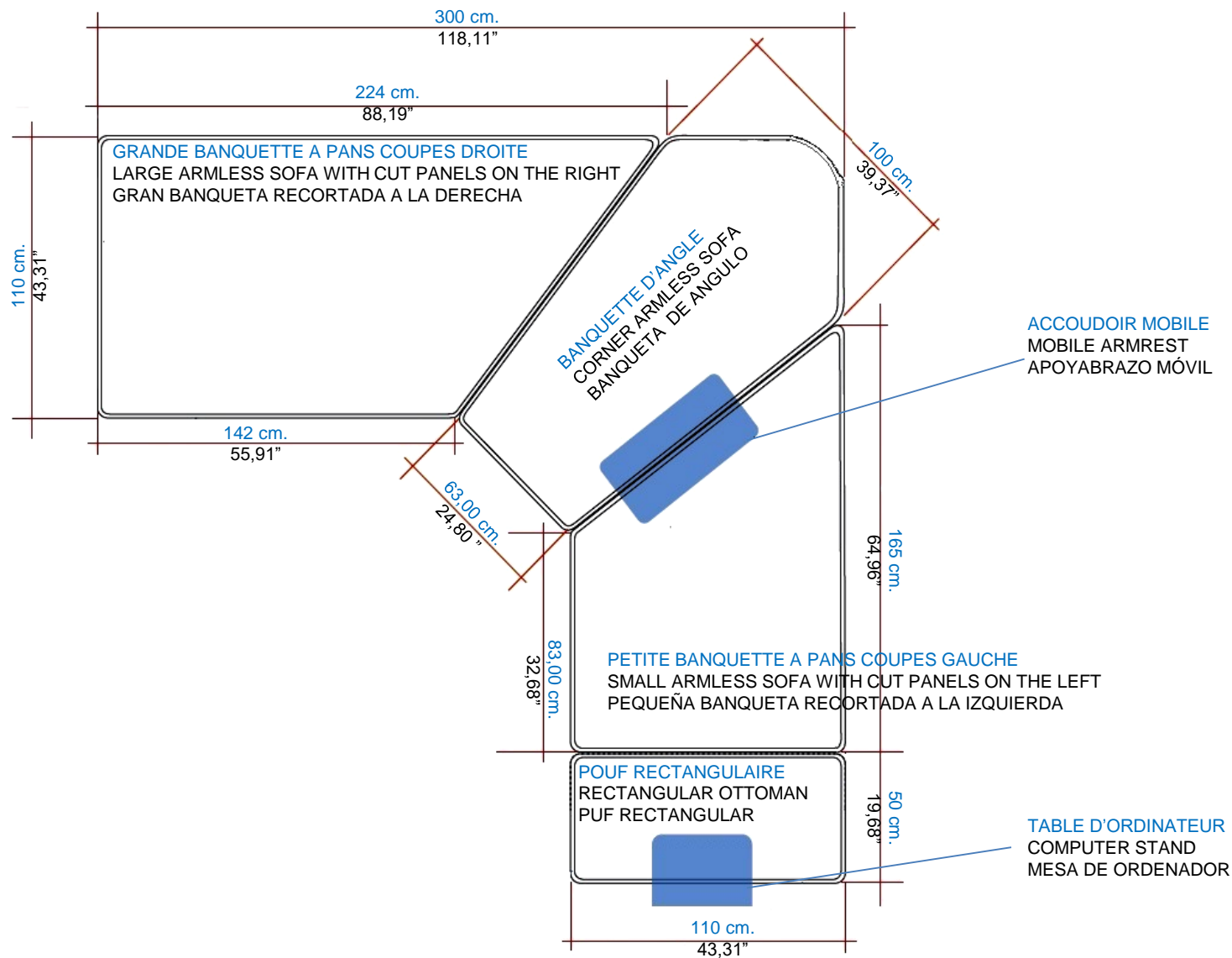

ESCAPADE 2

design Zeno NUGARI

GRANDE BANQUETTE A PANS COUPES DROITE
LARGE SOFA WITH CUT PANELS ON THE RIGHT
GRAN BANQUETA RECORTADA A LA DERECHA

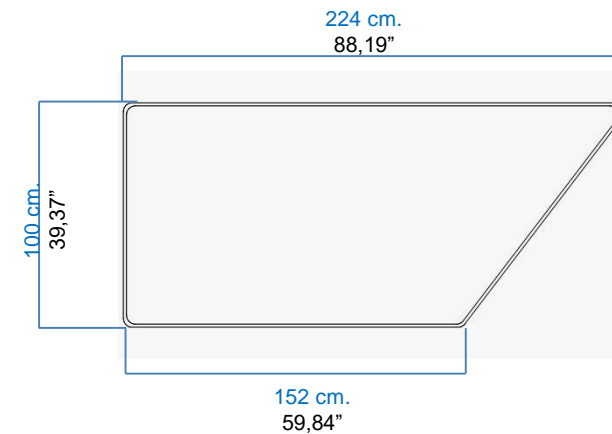
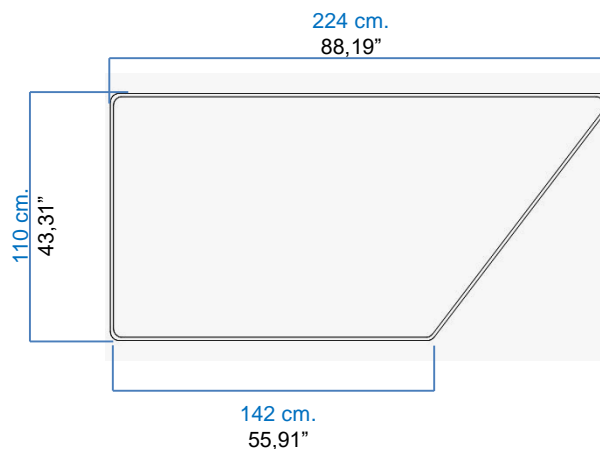
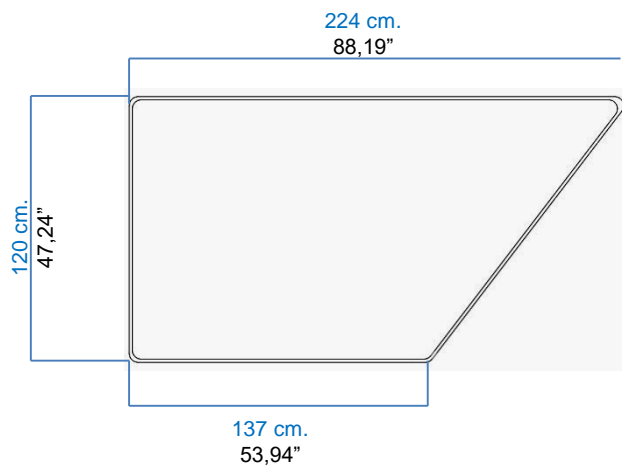

GRANDE BANQUETTE A PANS COUPES GAUCHE
LARGE SOFA WITH CUT PANELS ON THE LEFT
GRAN BANQUETA RECORTADA A LA IZQUIERDA

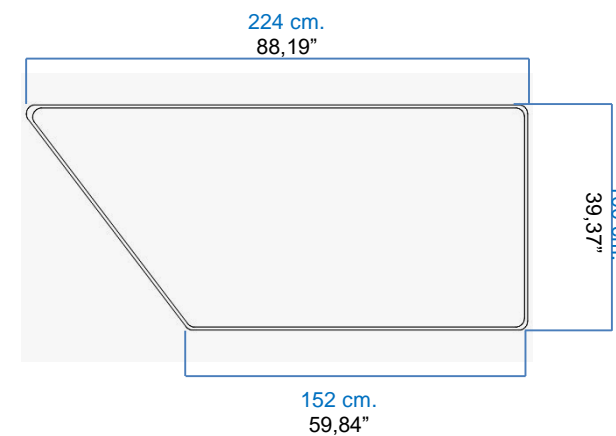
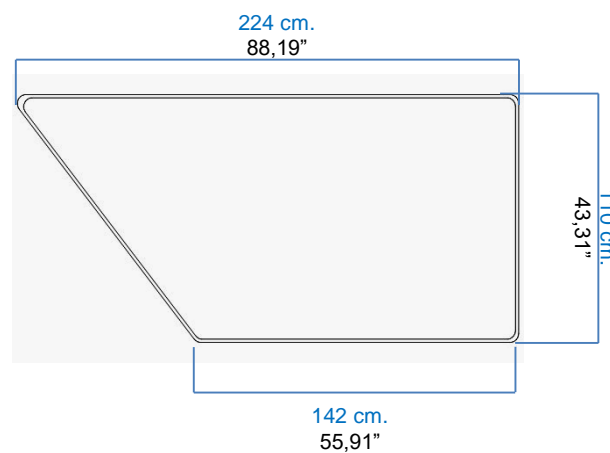
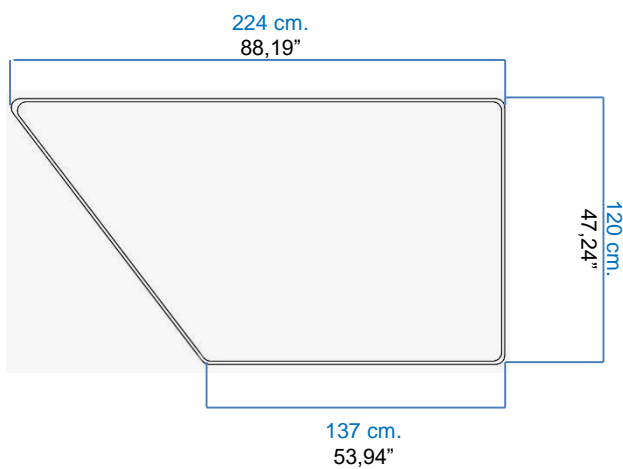

ESCAPADE 2

design Zeno NUGARI

PETITE BANQUETTE A PANS COUPES DROITE
SMALL SOFA WITH CUT PANELS ON THE RIGHT
PEQUEÑA BANQUETA RECORTADA A LA DERECHA

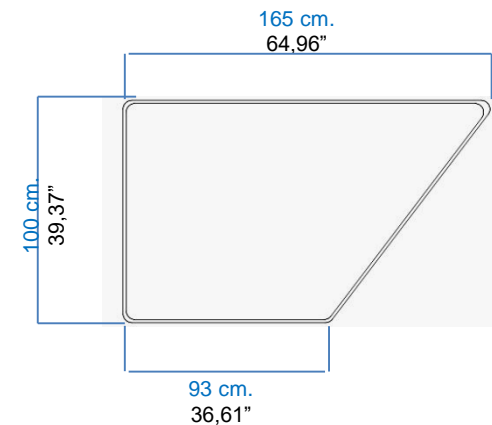
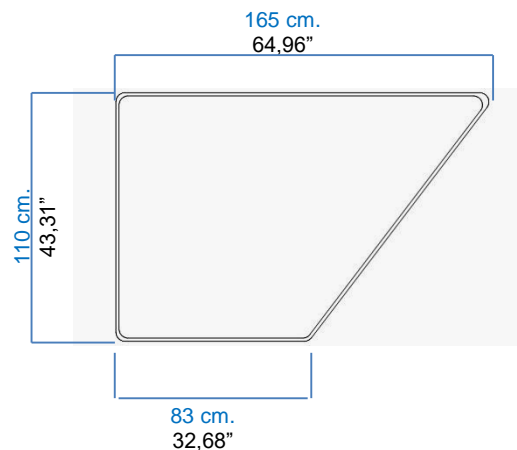
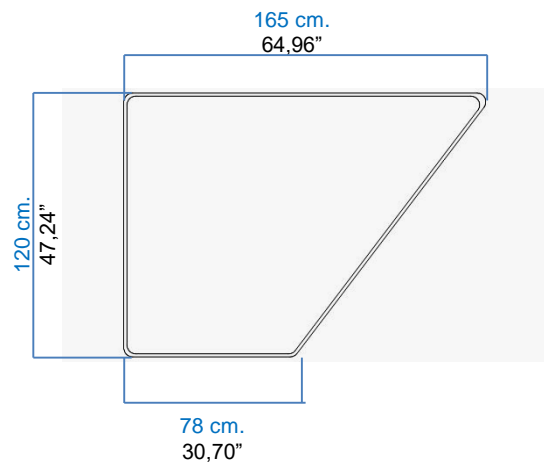

PETITE BANQUETTE A PANS COUPES GAUCHE
SMALL SOFA WITH CUT PANELS ON THE LEFT
PEQUEÑA BANQUETA RECORTADA A LA IZQUIERDA

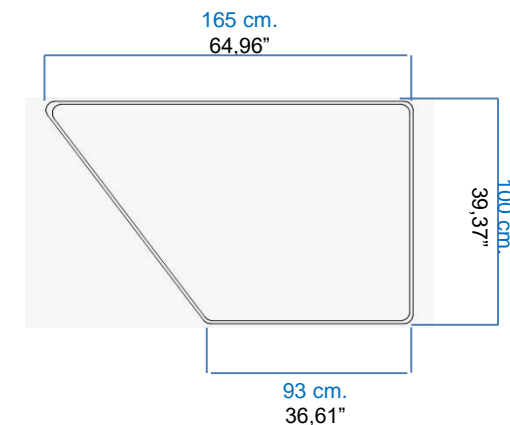
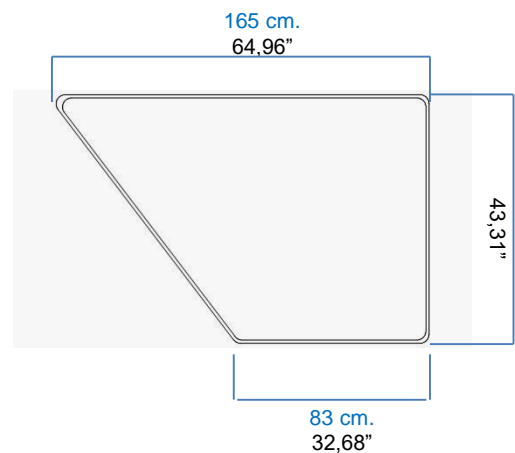
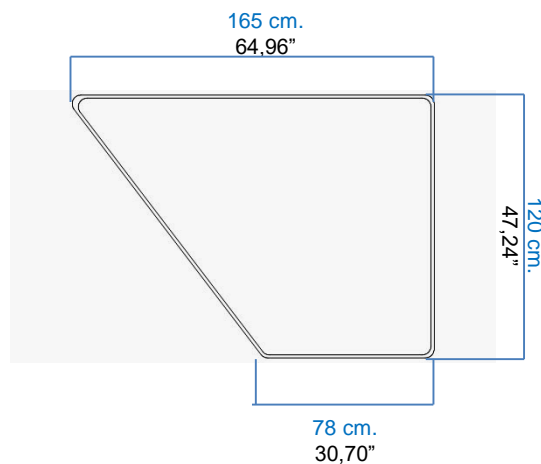

ESCAPADE 2

design Zeno NUGARI

BANQUETTE D'ANGLE PROF.120
CORNER ARMLESS SOFA DEPTH CM.120
BANQUETA DE ÁNGULO PROF.120

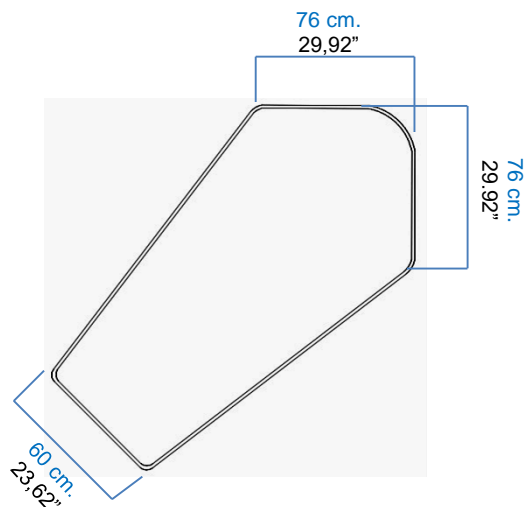

BANQUETTE D'ANGLE PROF.110
CORNER ARMLESS SOFA DEPTH CM.110
BANQUETA DE ÁNGULO PROF.110

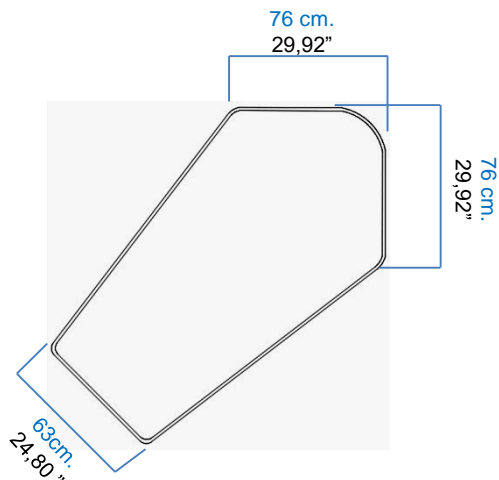

BANQUETTE D'ANGLE PROF.100
CORNER ARMLESS SOFA DEPTH.100
BANQUETA DE ÁNGULO PROF.100

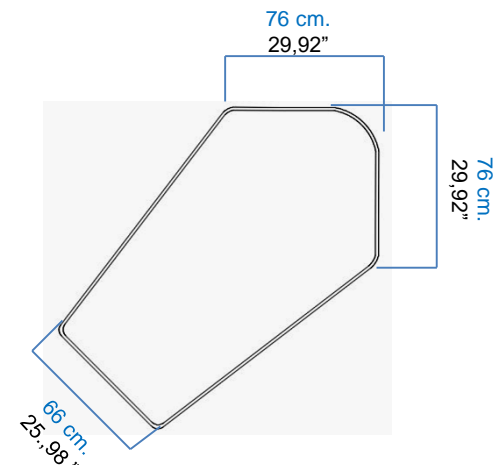

POUF RECTANGULAIRE
RECTANGULAR OTTOMAN
PUF RECTANGULAR

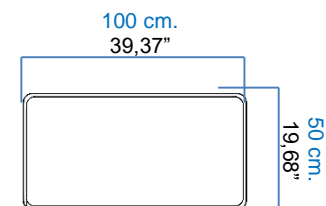
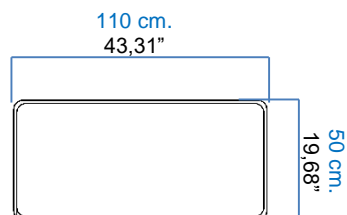
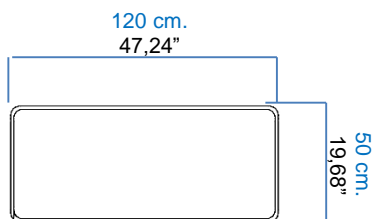

ESCAPADE 2

design Zeno NUGARI

GRAND POUF CARRE'
LARGE SQUARE OTTOMAN
GRAN PUF CUADRADO

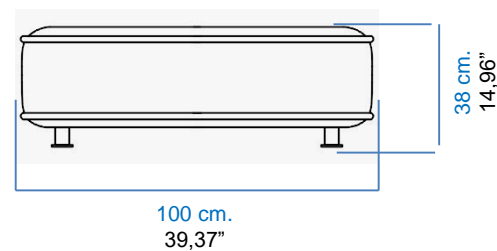
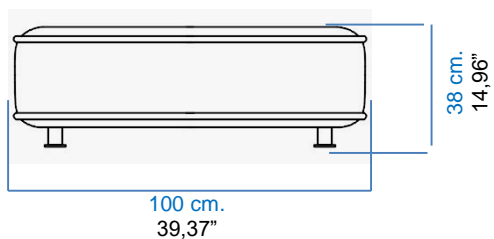

VUE DE COTE / SIDE VIEW / VISTA LATERAL

ACCOUDOIR MOBILE
MOBILE ARMREST
APOYABRAZO MÓVIL

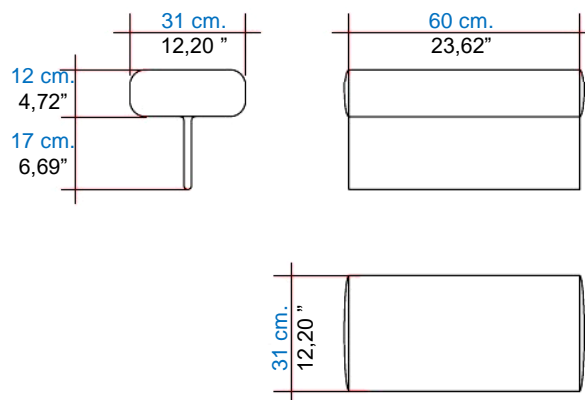

COUSSIN DE DOSSIER
BACKREST
COJÍN DE RESPALDO

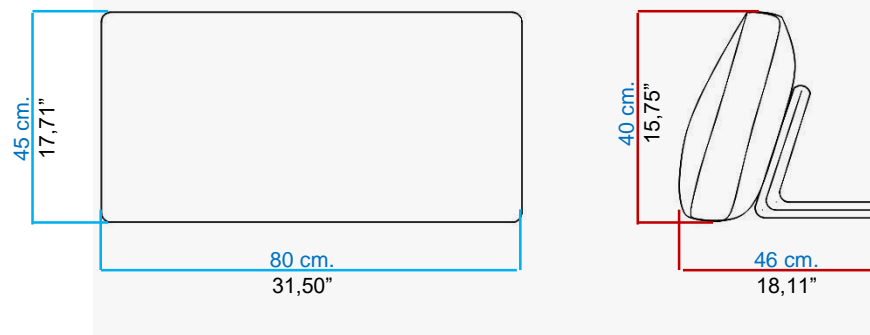

TABLE D'ORDINATEUR
COMPUTER STAND
MESA DE ORDENADOR

